

COLLECTION

Monpar 

Monpar

MADE IN ITALY, PRODOTTI CREATI DOVE DA SEMPRE NASCONO CAPOLAVORI.



Siamo nati e cresciuti in una terra che da sempre è culla dell'arte: le linee eleganti di Palladio, i colori vividi di Tiepolo, i raffinati gioielli cesellati dagli artigiani di Vicenza, capitale italiana dell'oro. Il "senso del bello" fa parte del nostro DNA, ci scorre nelle vene: ecco perché da Alonte, in provincia di Vicenza, portiamo in tutto il mondo pavimenti artigianali in legno che sono veri capolavori.

**MADE IN ITALY, GOODS CREATED
WHERE MASTERPIECES BORN SINCE EVER.**

We were born and grown in a land that is a cradle of art: elegant lines of Palladio, vivid colours of Tiepolo, refined chiselled jewels made by artisans of Vicenza, gold's capitol.

The "sense of beauty" is a part of our Dna, it is our artistic streak: this is the reason why from Alonte, in Vicenza's province, we export all around the world artisan wood floors that are real masterpieces.



INDEX

DESIGN COLLECTION - PAG. 8

MODULAR COLLECTION - PAG. 20

FINITURE / ESSENCES - PAG. 30

CARATTERISTICHE / FEATURES - PAG. 40

AMORE PER IL LEGNO E PER LA NATURA, RICERCA DI NUOVE TECNOLOGIE E MATERIALI DA LAVORARE, COSTANTE PASSIONE PER IL PROPRIO LAVORO. QUESTO È MONPAR.

Il legno è una materia viva: richiede cura, amore, attenzione.

Va rispettato, prima ancora che lavorato.

Con questa filosofia, da oltre 20 anni, Monpar realizza pavimenti in legno che valorizzano l'unicità della materia prima.

L'esperienza e la sensibilità maturati giorno dopo giorno, il respirare il profumo delle essenze naturali, l'accarezzare le superfici sempre diverse, l'osservazione delle mille venature e sfumature di tonalità, hanno arricchito il bagaglio di competenze dei nostri artigiani.

Ogni pavimento Monpar è un'opera d'arte unica, progettata e realizzata internamente in ogni fase di lavorazione, per ottenere un risultato che non si limiti semplicemente ad arredare, ma possa emozionare e farsi ammirare come una creazione di design.

Lo stesso rispetto e amore per il legno si confermano nella scelta di riutilizzare gli scarti di lavorazione: pezzi di legno, trucioli e segatura diventano la fonte dell'energia termica che riscalda i vari reparti dell'azienda durante il periodo invernale.

Tutto si trasforma, nulla si distrugge.

**LOVINESS FOR WOOD AND FOR ENVIROMENTAL,
REASEARCH IN NEW TECHNOLOGIES AND MATERIALS TO BE
WORKED, COSTANT PASSION FOR OWN WORK. THIS IS MONPAR**

Wood is live material: it needs care, love, attention.

Need to be respected it, first to be worked.

With this philosophy, Monpar realizes wood floors that value the uniqueness of the raw material from more than 20 years.

The experience and the sensibility gained day by day, the breathing the perfumes of each single noble woods, brushing surfaces always different, the observance of all grains and tones, had enriched the knowledge baggage of our artisans. Every Monpar's wood floors it is a unique art work, totally realized not only for furnishing but for exciting and creating a design sensation.

The same respect and love for the wood bring us in the environmental choice to recycle all wastes to heat all departments of the factory during winter time. Everything becomes, nothing is destroyed.





LAVORAZIONI E PRODOTTI DI QUALITÀ CERTIFICATA.

Anche un lavoro dall'anima antica come il nostro richiede un continuo aggiornamento tecnologico ricercando costantemente i più moderni macchinari e scegliendo le soluzioni produttive con le più evolute tecniche.

Il nostro amore per la natura non è un semplice slogan, ma una realtà concreta: la certificazione PEFC ed FSC garantiscono il rispetto per le più rigorose normative ambientali. La marchiatura CE e l'organizzazione aziendale secondo gli standard ISO 9001 rendono Monpar un'azienda capace di affrontare ogni mercato.

WORKSHIP AND PRODUCTS OF CERTIFIED QUALITY.

Also an ancient soul work as our, needs a constant technological revised searching all time the most modern machinery and updating production's solution with the newest techniques.

Our love for nature it is not a simple slogan, but a concrete reality: PEFC and FSC certifications guarantee the respect of the most strict environmental rules. CE mark together with ISO 9001 certificate, make Monpar a modern company able to take on any new market's challenge.

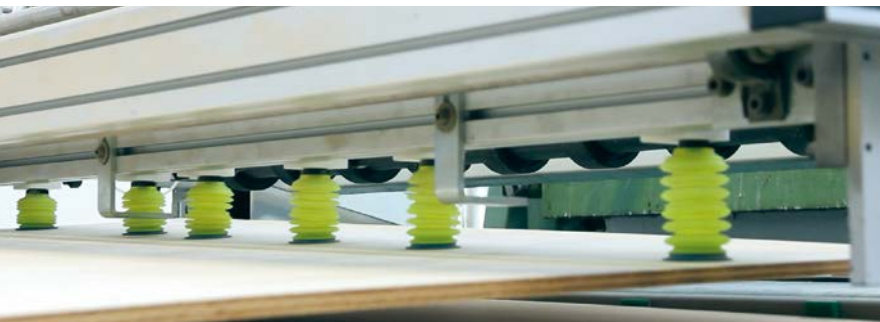



LA RICERCA DELLA MATERIA PRIMA, L'ATTENTA SELEZIONE, LA CURA NEL TRATTAMENTO E NELLE FINITURE: NOI LAVORIAMO COSÌ.

Monpar seleziona le migliori essenze di tutto il mondo grazie alla decennale esperienza del proprio staff e ad un'attenta selezione dei propri fornitori.

Le essenze, provenienti da foreste controllate e certificate secondo i più moderni standard, vengono lavorate con l'esclusivo utilizzo di colle viniliche completamente prive di emissioni nocive, garantendo e certificando un'eccellente qualità. A questo va aggiunta una costante ricerca di oli naturali e di vernici all'acqua di ultima generazione per rispettare sempre l'ambiente circostante.

Monpar personalizza finiture all'interno di ogni singola collezione, apportando specifiche soluzioni tecniche e tecnologiche nel rispetto delle più recenti normative nazionali ed internazionali.

*THE RESEARCH OF RAW MATERIALS, THE ATTENTION
ON SELECTION, THE CARE IN TREATMENT AND FINISHINGS:
WE WORK LIKE THIS.*

Monpar selects the best essences around the world thanks to the ten-year experience of its staff and to the strong selection of its suppliers.

All essences, coming from certified and controlled forests under latest and modern standards, are worked with exclusive use of vinyl glue totally without noxious emissions guaranteeing and certifying an excellent quality. Also add to this a constant research of last generation neutral oils and water based varnish for environmental respect but also for the domestic life of every day. At the end, Monpar do a rigid final selection to customized every single collection, underlining and valuing clear characteristics in respect of the last national and international rules.

LAVORAZIONI A MACCHINA / MACHINERY PROCESSING



PRELEVIGATO POLISHED

Levigatura fine eseguita con macchinari professionali per ottenere una superficie particolarmente liscia al tatto ed uniforme alla vista.

Made by high precision machinery to obtain a perfect and uniform surface.



SPAZZOLATO BRUSHED

Lavorazione eseguita con macchinari professionali muniti di spazzole che rimuovono la parte più tenera della venatura, lasciando intatta la fibra del legno più dura. Effetto seta al tatto.

Made by high technology machinery equipped with brushes able to remove the tender part of the wood maintaining intact the harder fibre.



TAGLIO SEGA SAW CUT

Particolare lavorazione che rende la superficie ruvida, scanalata a ricordo delle vecchie lavorazioni con vecchie seghe. La lavorazione non si ripete regolarmente come effetto meccanico ma lascia intravedere i segni a rilievo senza stressare la tavola.

Very characteristic process that replicate the old saw mill effect. It is no repetitive and leaves not stressed the board.

LAVORAZIONI A MANO / HANDMADE PROCESSING



PIALLATO A MACCHINA CON FINITURA A MANO PLANED BY MACHINE AND HAND FINISHED

Lavorazione eseguita a macchina ma rifinita a mano per togliere l'effetto scolpito della macchina rendendo il pavimento morbido al tatto.

Process made by machine but ulimated by hand to remove the irregular scrapes and to give a soft touch to the floor.



PIALLATO A MANO HAND PLANED

Lavorazione della superficie a cura del maestro artigiano che con tradizionale pialla a lama, crea una piallatura irregolare rendendo il pavimento particolarmente morbido al tatto dal sapore vissuto.

Characteristic handy made finished realized by our artisans that using old tools create an irregular effect giving a soft touch to the floor that infuses antique flavour.



MANUALIS

Esclusiva lavorazione eseguita interamente a mano dal maestro artigiano il quale, con pazienza leviga la superficie disponendo casualmente gli avvallamenti che esaltano la sensazione del consumato, creando un effetto naturale invecchiato.

Totally handmade by the master artisan that scrupulously scrapes and plans the wood in a casual way, replicating processing of the past.

BY CARLO DAL BIANCO

Carlo Dal Bianco, architetto e designer, apre il suo studio nel 1993 a Vicenza.

Si occupa per diversi anni di restauro di edifici di interesse storico-monumentale.

Nel 2001 inizia la collaborazione con Bisazza, azienda leader nel mondo del mosaico, per la quale ristruttura interamente la nuova sede, disegna gran parte dei prodotti e dei decori e progetta le quattordici showroom Bisazza nel mondo.

Nel 2004 fonda e dirige il Bisazza Design Studio e disegna per Bisazza Home.

Vince per due volte, nel 2004 e nel 2006, il premio Elle Decoration International Awards.

Nel 2008, chiamato da Michael Sieger, progetta un servizio in porcellana per l'alta gastronomia per "Porzellanmanufaktur Fuerstenberg GmbH".

Dal 2011 collabora anche con altre prestigiose aziende tra cui Rapsel e Rexa Design.

Carlo Dal Bianco, architect and designer, opened his design studio in 1993 in Vicenza - Italy.

He worked for several years on historic and monumental building restoration.

In 2001 he started his partnership with Bisazza, world leader factory in mosaic production, for whom he restored the headquarter completely. He also designed for them many collections and all the 14 show rooms all around the world. In 2014 he founded "Bisazza Design Studio" and began to design for Bisazza Home. He won Elle Decoration International Awards twice, in the 2004 and 2006. In 2008, called by Michael Siager, designed a porcelain set for haute cuisine for "Porzellanmanufaktur Fuerstenberg GmbH".

From 2001 also works for other prestigious factories as Rapsel and Rexa Design.

DESIGN COLLECTION

Monpar 

LUNGO ESAGONO

Lungo esagono carbonato visone oliato
Long hexagon thermowood visone oiled

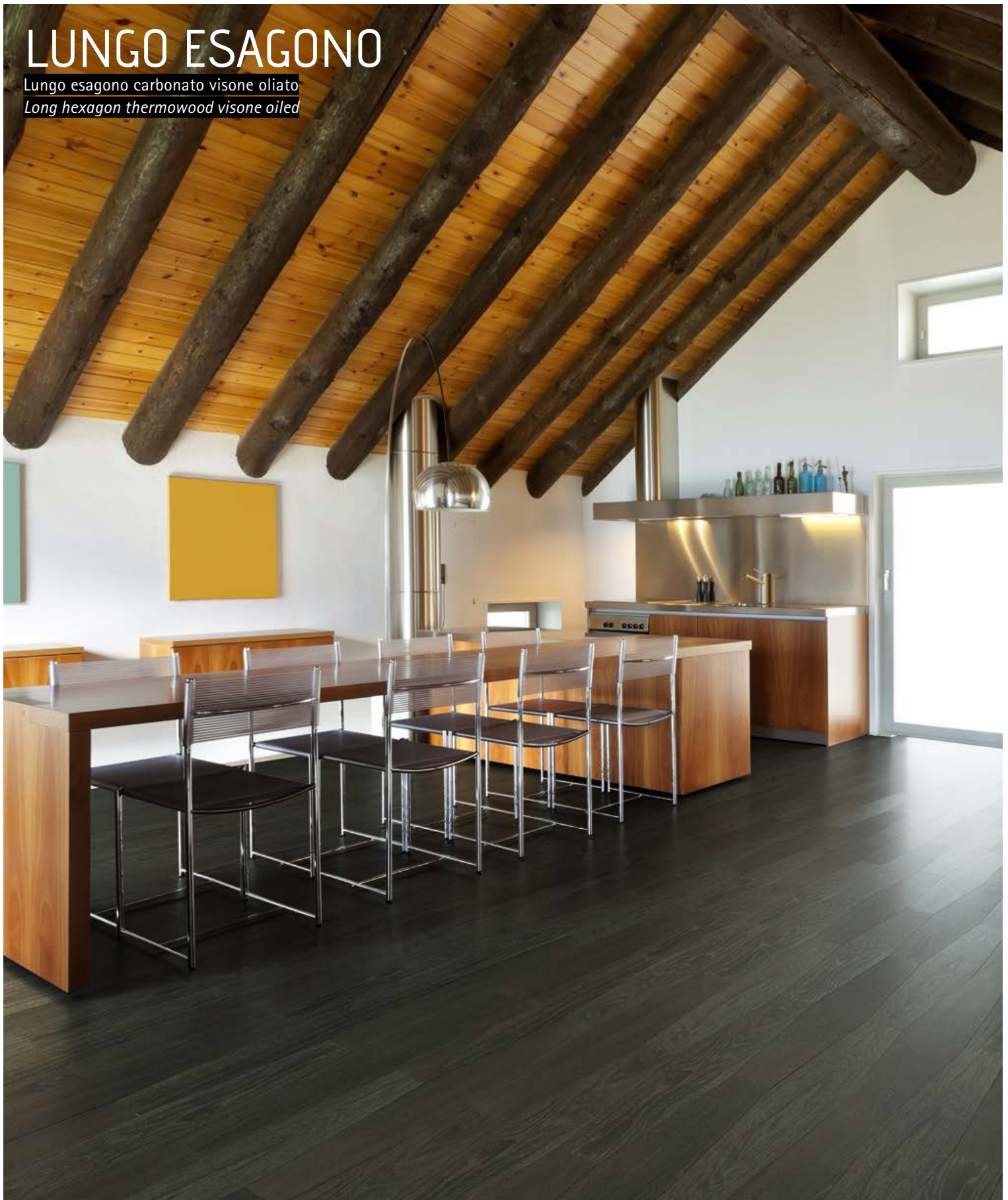



posa 1



Lungo esagono sabbia
spazzolato verniciato
*Long Hexagon sabbia
brushed varnished*



Lungo esagono
carbonato taglio sega
verniciato
*Long Hexagon
thermowood saw/cut
varnished*



Lungo esagono
carbonato visone taglio
sega oliato
*Long Hexagon
thermowood visone
saw/cut oiled*



Lungo esagono
carbonato fumè bianco
taglio sega verniciato
*Long Hexagon
thermowood fumè white
saw/cut varnished*





posa 1



posa 2

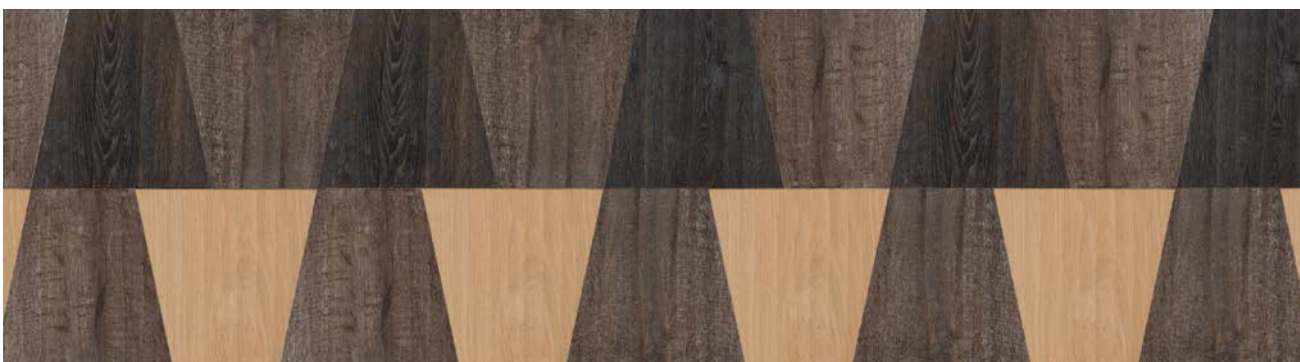

posa 3



Piccolo Vaso Piallato
Verniciato Sabbia
*Small Vase Planed
Varnished Sabbia*



Piccolo Vaso Piallato
Verniciato Champagne
*Small Vase Planed
Varnished Champagne*



Piccolo Vaso Piallato
Oliato Visone
*Small Vase Planed
Oiled Visone*



Piccolo Vaso Piallato
Verniciato Antracite
*Small Vase Planed
Varnished Antracite*



PICCOLO VASO

posa 4



Lungo Esagono Spazzolato Verniciato Sabbia
Long Hexagon Brushed Varnished Sabbia

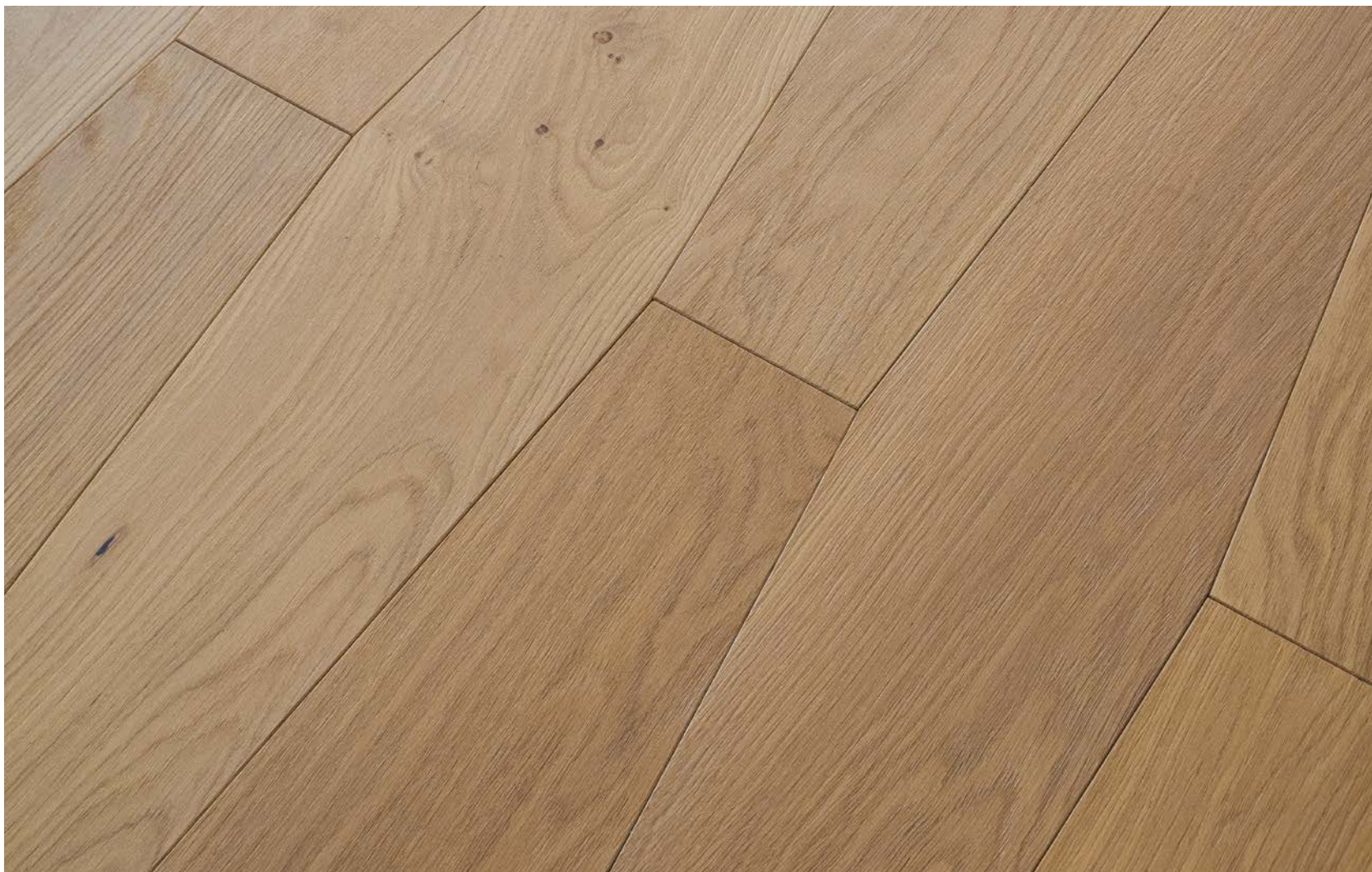



Piccolo Vaso Piallato Oliato Visone
Small Vase Planed Oiled Visone





Lungo Esagono Spazzolato Verniciato Sabbia
Long Hexagon Brushed Varnished Sabbia







GRANDE SPINA

Spazzolato Verniciato Sabbia
Brushed Varnished Sabbia





Grande Spina Spazzolato Verniciato Sabbia
Big Spine Brushed Varnished Sabbia



Grande Spina Spazzolato Verniciato Champagne
Big Spine Brushed Varnished Champagne



Grande Spina Spazzolato Verniciato Barberini
Big Spine Brushed Varnished Barberini



Grande Spina Antracite Spazzolato Verniciato
Big Spine Antracite Brushed Varnished





MODULAR COLLECTION

Monpar 



Rovere Carbonato Verniciato all'Acqua
Oak Thermo Water Based Varnished



3D THERMO

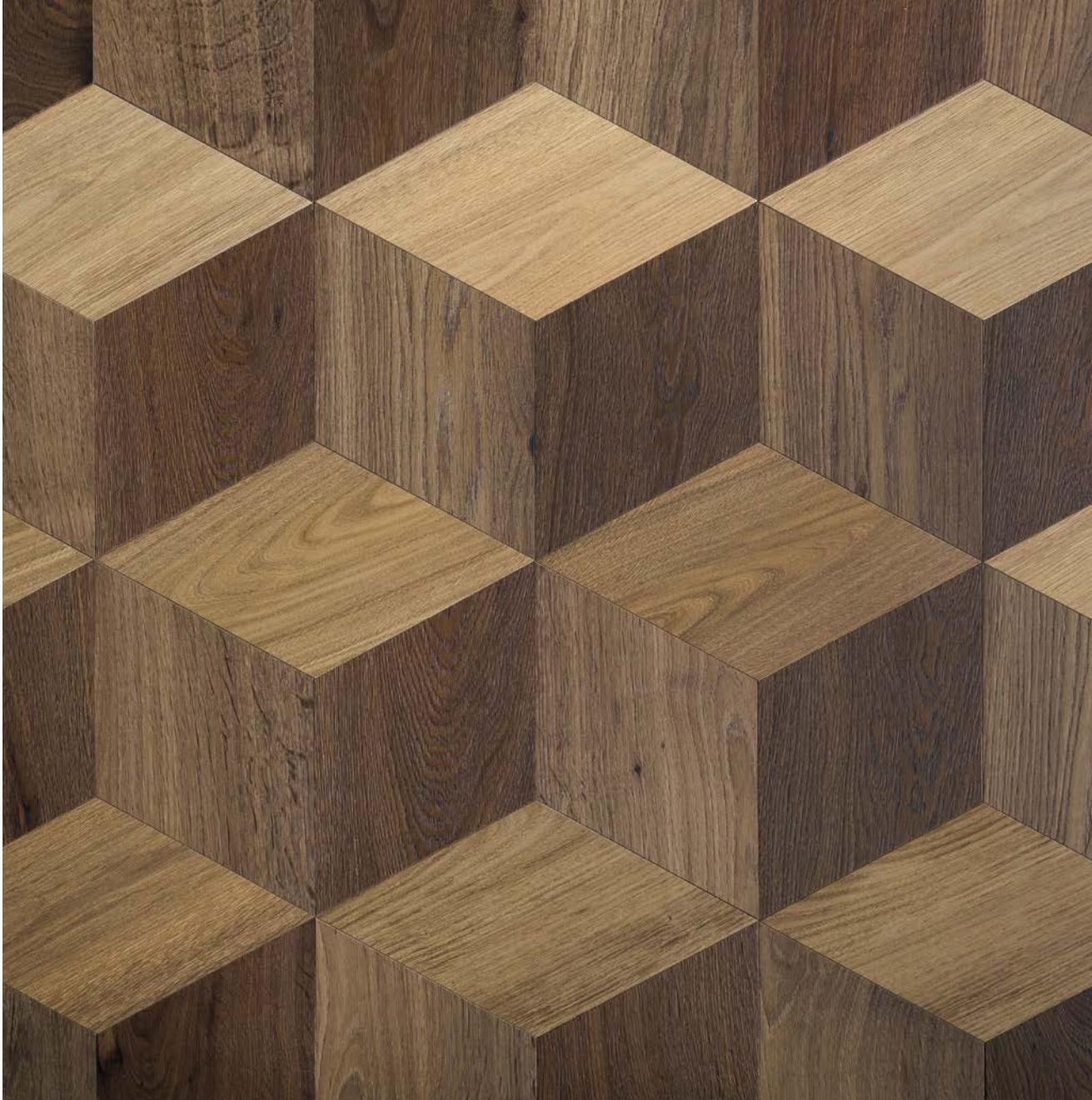

Rovere Carbonato Verniciato all'Acqua
Oak Thermo Water Based Varnished



QUADRO



Rovere Spazzolato Verniciato
Oak Brushed Varnished

Islanda
Antracite



THUNDER

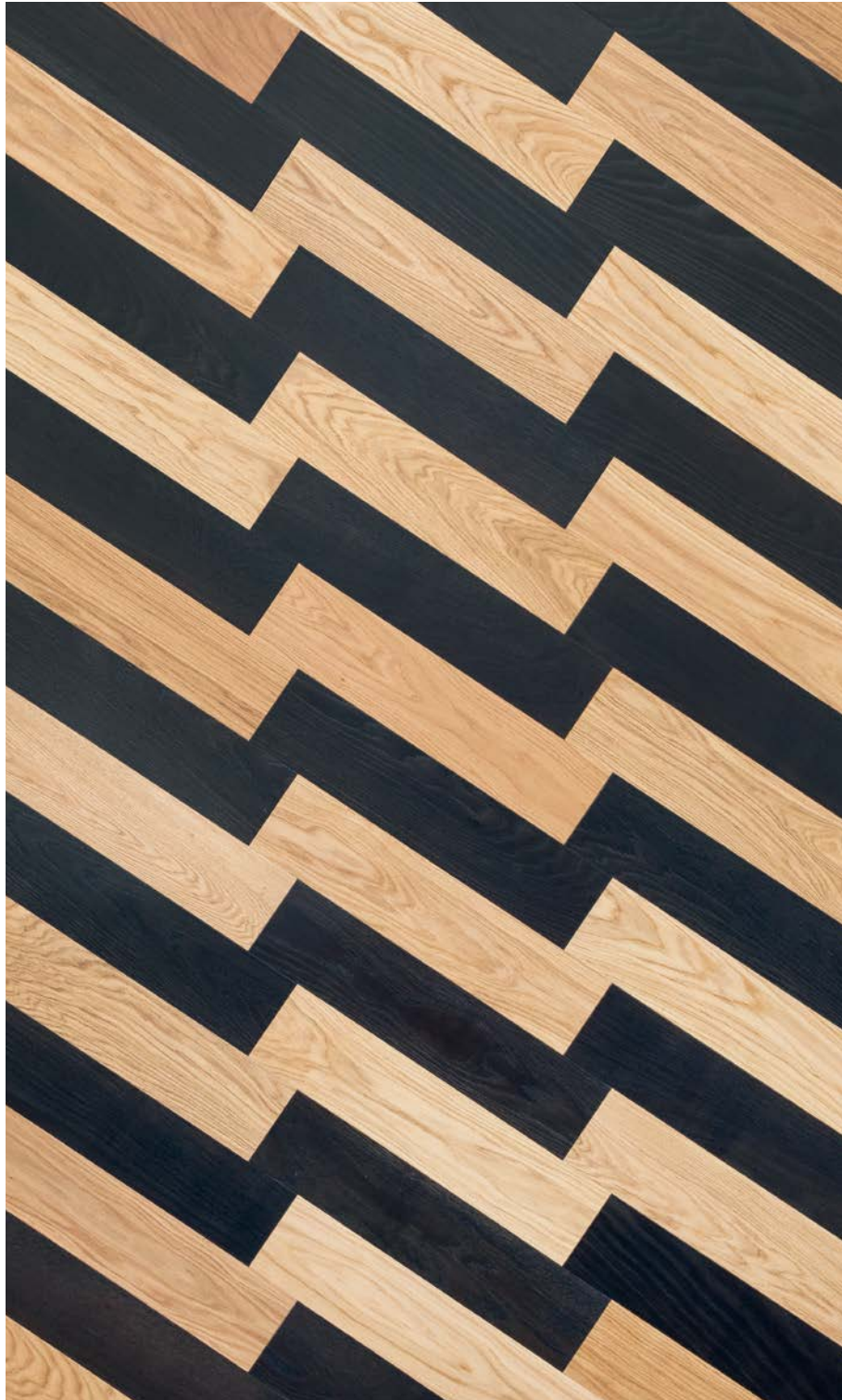

Rovere Spazzolato
Verniciato
Oak Brushed Varnished

Antracite / Naturale



TRAMA



Rovere Spazzolato
Verniciato
Oak Brushed
Varnished

309/6
Metal Champagne



PATCHWORK

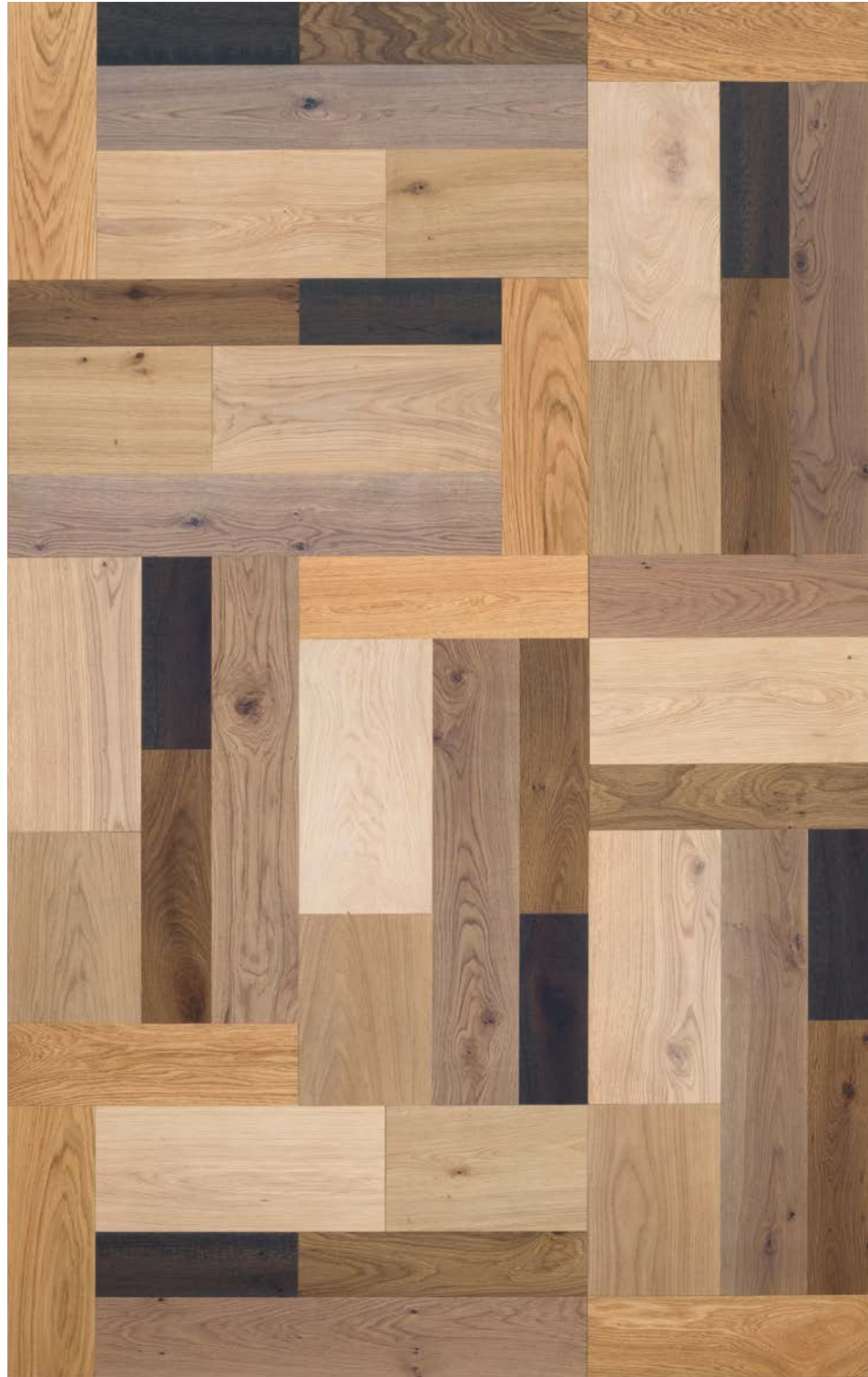

Rovere Spazzolato
Verniciato
Oak Brushed
Varnished

Metal Champagne
Nubium
Antracite
Casale 28
Vecchia Umbria
Naturale



INDIAN PATTERN



Indian Pattern
Rovere Carbonato
Spazzolato
Verniciato all'Acqua

*Indian Pattern
Oak Thermowood
Brushed Water
Based Varnished*



DESIGN MODULAR

FINITURE ESSENCES

Monpar 

ESSENZA ROVERE / OAK



NATURALE

superficie: spazzolato / prelevigato / taglio sega / piallato
surface: brushed / polished / saw cut / planed

finitura: verniciato
finish: varnished



NATURALE ALL'ACQUA

superficie: spazzolato / prelevigato / taglio sega / piallato
surface: brushed / polished / saw cut / planed

finitura: verniciato all'acqua
finish: water based varnished



ECOWOOD

superficie: spazzolato / prelevigato / taglio sega / piallato
surface: brushed / polished / saw cut / planed

finitura: verniciato all'acqua
finish: water based varnished



BIANCO PLUS

superficie: spazzolato / prelevigato / taglio sega / piallato
surface: brushed / polished / saw cut / planed

finitura: verniciato
finish: varnished



BIANCO

superficie: spazzolato / prelevigato / taglio sega / piallato
surface: brushed / polished / saw cut / planed

finitura: verniciato
finish: varnished



JEANS BIANCO

superficie: spazzolato / taglio sega / piallato
surface: brushed / saw cut / planed

finitura: verniciato
finish: varnished



VENEZIA 1610

superficie: spazzolato / prelevigato / taglio sega / piallato
surface: brushed / polished / saw cut / planed

finitura: verniciato
finish: varnished



SABBIA

superficie: spazzolato / prelevigato / taglio sega / piallato
surface: brushed / polished / saw cut / planed

finitura: verniciato
finish: varnished



GHIBLI DECAPATO

superficie: spazzolato / taglio sega / piallato
surface: brushed / saw cut / planed

finitura: verniciato
finish: varnished



VINTAGE GRIGIO FUMO

superficie: spazzolato / prelevigato / taglio sega / piallato
surface: brushed / polished / saw cut / planed

finitura: verniciato
finish: varnished



ESSENZA ROVERE / OAK



NEW AGE GOLD

superficie: spazzolato / prelevigato / taglio sega / piallato
surface: brushed / polished / saw cut / planed

finitura: verniciato
finish: varnished



NUBIUM

superficie: spazzolato / prelevigato / taglio sega / piallato
surface: brushed / polished / saw cut / planed

finitura: verniciato
finish: varnished



ONE & ONLY

superficie: prelevigato
surface: polished

finitura: verniciato
finish: varnished



CHAMPAGNE

superficie: spazzolato / prelevigato / taglio sega / piallato
surface: brushed / polished / saw cut / planed

finitura: verniciato
finish: varnished



CARBONATO

superficie: spazzolato / prelevigato / taglio sega / piallato
surface: brushed / polished / saw cut / planed

finitura: verniciato
finish: varnished



TINTO NOCE

superficie: spazzolato / prelevigato / taglio sega / piallato
surface: brushed / polished / saw cut / planed

finitura: verniciato
finish: varnished



DAMASCO

superficie: spazzolato / taglio sega / piallato
surface: brushed / saw cut / planed

finitura: verniciato
finish: varnished



ISLANDA

superficie: spazzolato / taglio sega / piallato
surface: brushed / saw cut / planed

finitura: verniciato
finish: varnished



TERRA 309/6

superficie: spazzolato / taglio sega / piallato
surface: brushed / saw cut / planed

finitura: verniciato
finish: varnished



CASALE 28

superficie: spazzolato / prelevigato / taglio sega / piallato
surface: brushed / polished / saw cut / planed

finitura: verniciato
finish: varnished



COGNAC

superficie: spazzolato / prelevigato / taglio sega / piallato
surface: brushed / polished / saw cut / planed

finitura: verniciato
finish: varnished



METAL CHAMPAGNE

superficie: spazzolato / prelevigato / taglio sega / piallato
surface: brushed / polished / saw cut / planed

finitura: verniciato
finish: varnished

ESSENZA ROVERE / OAK

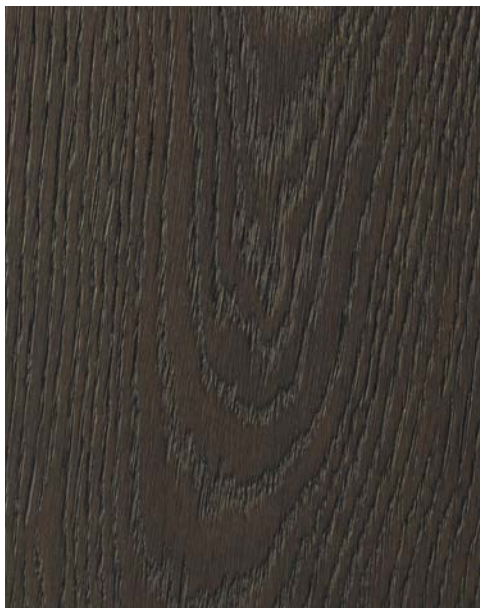

CARBONATO SOSPIRI

superficie: spazzolato / prelevigato / taglio sega / piallato
surface: brushed / polished / saw cut / planed

finitura: verniciato
finish: varnished



CARBONATO VECCHIA UMBRIA ALL'ACQUA

superficie: spazzolato / prelevigato / taglio sega / piallato
surface: brushed / polished / saw cut / planed

finitura: verniciato all'acqua
finish: water based varnished



MOKA DECAPATO BEIGE

superficie: spazzolato / taglio sega / piallato
surface: brushed / saw cut / planed

finitura: verniciato
finish: varnished



BARBERINI DECAPATO BEIGE

superficie: spazzolato / taglio sega / piallato
surface: brushed / saw cut / planed

finitura: verniciato
finish: varnished



BARBERINI

superficie: spazzolato / prelevigato / taglio sega / piallato
surface: brushed / polished / saw cut / planed

finitura: verniciato
finish: varnished



TESTA DI MORO

superficie: spazzolato / prelevigato / taglio sega / piallato
surface: brushed / polished / saw cut / planed

finitura: verniciato
finish: varnished

Residenza Privata
Rovere Spazzolato Oliato Visone
Oak Brushed Oiled Visone

ESSENZA ROVERE / OAK



NEW AGE SILVER

superficie: spazzolato / prelevigato / taglio sega / piallato
surface: brushed / polished / saw cut / planed

finitura: verniciato
finish: varnished



GRIGIO

superficie: spazzolato / prelevigato / taglio sega / piallato
surface: brushed / polished / saw cut / planed

finitura: verniciato
finish: varnished



GRIGIO PATINATO

superficie: spazzolato / taglio sega / piallato
surface: brushed / saw cut / planed

finitura: verniciato
finish: varnished



GRIGIO 309/10

superficie: spazzolato / taglio sega / piallato
surface: brushed / saw cut / planed

finitura: verniciato
finish: varnished



GRIGIO PERLA

superficie: spazzolato / prelevigato / taglio sega / piallato
surface: brushed / polished / saw cut / planed

finitura: verniciato
finish: varnished



VINTAGE VISONE

superficie: spazzolato / prelevigato / taglio sega / piallato
surface: brushed / polished / saw cut / planed

finitura: oliato
finish: oiled



ANTRACITE

superficie: spazzolato / prelevigato / taglio sega / piallato
surface: brushed / polished / saw cut / planed

finitura: verniciato
finish: varnished



NEW AGE MOKA

superficie: spazzolato / prelevigato / taglio sega / piallato
surface: brushed / polished / saw cut / planed

finitura: verniciato
finish: varnished

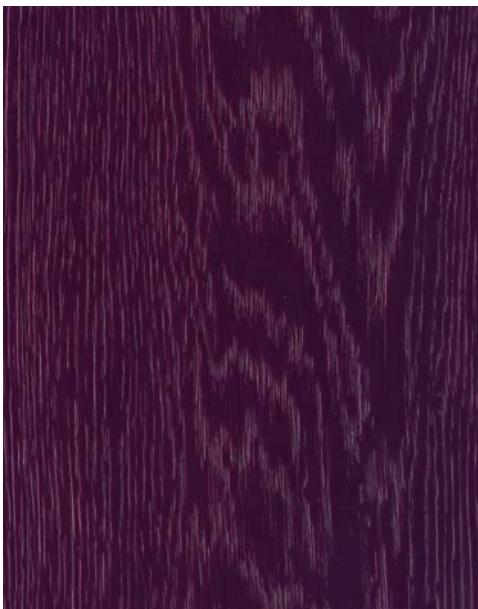

RAL 4007

superficie: spazzolato / prelevigato / taglio sega / piallato
surface: brushed / polished / saw cut / planed

finitura: verniciato
finish: varnished



RAL 7006

superficie: spazzolato
surface: brushed

finitura: verniciato
finish: varnished

DESIGN MODULAR

CARATTERISTICHE FEATURES

Monpar 

DESIGN LUNGO ESAGONO BASE FOLK

Plancia: <i>Plank:</i>	due strati <i>two plank</i>
	
Spessore: <i>Thickness:</i>	15-16 mm
Strato nobile: <i>Noble layer:</i>	4 mm (nominale) <i>4 mm (nominal)</i>
Supporto: <i>Feature:</i>	Due strati: (4 mm) strato superiore in essenza nobile, (12 mm) supporto in multistrato di betulla Two layer: (4 mm) top layer in noble wood, (12 mm) support in multilayer birch plywood
Misure: <i>Size:</i>	Spessore 15 mm, larghezza 190 mm, lunghezza 920 mm <i>Thickness 15 mm, width 190 mm, lenght 920 mm</i>
Certificazioni: <i>Certifications:</i>	PEFC, FSC, Prodotto Fabbrica Italiana, CE <i>PEFC, FSC, Prodotto Fabbrica Italiana, CE</i>
Lavorazione: <i>Manufacturing:</i>	Incastro sui quattro lati con leggera bisellatura incastro femmina / femmina <i>Four slightly chamfered sides locked together tongue / tongue</i>
Qualità: <i>Quality:</i>	Risponde alla normativa Uni En 13489 <i>According to Uni En 13489 rule</i>
Tipo di posa: <i>Laying:</i>	Incollato su massetto con specifica colla per pavimenti <i>Only glued down</i>
Superfici: <i>Surfaces:</i>	Prelevigato, Spazzolato, Piallato, T/Sega <i>Polished, Brushed, Hand Planed, Saw/cut</i>
Superfici: <i>Surfaces:</i>	Olio Naturale Bioil, Olio Uretanico, Vernice Poliuretanic, Vernice all'Acqua <i>Neutral Oil Bioil, Urethane Oil, Polyurethane Varnish, Water Based Varnished</i>

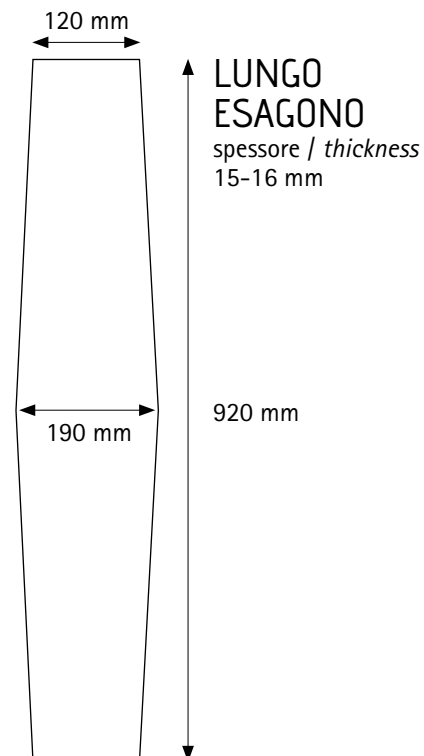

DESIGN PICCOLO VASO BASE PERLA

DESIGN GRANDE SPINA BASE PERLA

Plancia: <i>Plank:</i>	tre strati <i>layers plank</i>	
		
Spessore: <i>Thickness:</i>	15 mm	15 mm
Strato nobile: <i>Noble layer:</i>	4 mm (nominale) <i>4 mm (nominal)</i>	
Supporto: <i>Feature:</i>	Tre strati: (4 mm) strato nobile in essenza nobile, (7 mm) strato centrale in abete, (4 mm) strato inferiore in essenza controbilanciante Three layer: (4 mm) top layer in noble wood, (7 mm) central layer solid pine, (4 mm) bottom layer selected wood to counterbalance	
Misure: <i>Size:</i>	Spessore 15 mm, larghezza 300 mm, lunghezza 300 mm <i>Thickness 15 mm, width 300 mm length 300 mm</i>	Spessore 15 mm, larghezza 300 mm, lunghezza 600 mm <i>Thickness 15 mm, width 300 mm, length 600 mm</i>
Certificazioni: <i>Certifications:</i>	PEFC, FSC, Prodotto Fabbrica Italiana, CE <i>PEFC, FSC, Prodotto Fabbrica Italiana, CE</i>	
Lavorazione: <i>Manufacturing:</i>	Incastro sui quattro lati con leggera bisellatura incastro femmina / femmina <i>Four slightly chamfered sides locked together tongue / tongue</i>	
Qualità: <i>Quality:</i>	Risponde alla normativa Uni En 13489 <i>According to Uni En 13489 rule</i>	
Tipo di posa: <i>Laying:</i>	Incollato su massetto con specifica colla per pavimenti <i>Only glued down</i>	
Superfici: <i>Surfaces:</i>	Prelevigato, Spazzolato, Piallato, T/Sega <i>Polished, Brushed, Hand Planed, Saw/cut</i>	
Superfici: <i>Surfaces:</i>	Olio Naturale Bioil, Olio Uretanico, Vernice Poliuretana, Vernice all'Acqua <i>Neutral Oil Bioil, Urethane Oil, Polyurethane Varnish, Water Based Varnished</i>	

PICCOLO VASO

spessore / *thickness* 15 mm

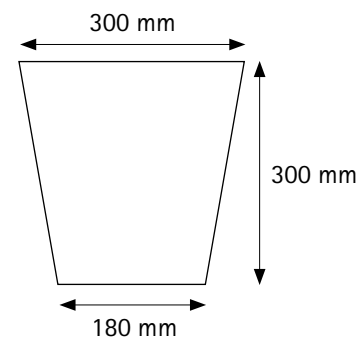

GRANDE SPINA

spessore / *thickness* 15 mm

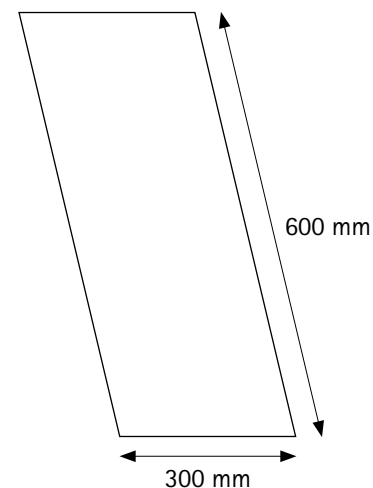

MODULAR BASE FOLK

Plancia: <i>Plank:</i>	due strati <i>two plank</i>
	
Spessore: <i>Thickness:</i>	15 - 16 mm
Strato nobile: <i>Noble layer:</i>	4 mm (nominale) <i>4 mm (nominal)</i>
Supporto: <i>Feature:</i>	Due strati: (4 mm) strato superiore in essenza nobile, (12 mm) supporto in multistrato di betulla <i>Two layer:</i> <i>(4 mm) top layer in noble wood,</i> <i>(12 mm) support in multilayer birch plywood</i>
Certificazioni: <i>Certifications:</i>	PEFC, FSC, Prodotto Fabbrica Italiana, CE <i>PEFC, FSC, Prodotto Fabbrica Italiana, CE</i>
Lavorazione: <i>Manufacturing:</i>	Bisellatura sui quattro lati con incastro maschio/femmina (escluso 3D Thermo e Indian Patern femmina/femmina) <i>Four slightly chamfered sides locked together tongue/groove connection (except 3D Thermo and Indian Patern fogue/tongue)</i>
Qualità: <i>Quality:</i>	Risponde alla normativa Uni En 13489 <i>According to Uni En 13489 rule</i>
Tipo di posa: <i>Laying:</i>	Incollata su massetto con apposita colla per pavimenti <i>Glued down</i>
Superfici: <i>Surfaces:</i>	Prelevigato, Spazzolato, Piallato, T/sega <i>Polished, Brushed, Hand Planed, Saw/cut</i>
Finiture: <i>Finishes:</i>	Olio naturale Bioil, Olio Uretanico, Vernice Poliuretana, Vernice all'acqua. <i>Neutral Oil Bioil, Urethane Oil, Polyurethane Varnish, Water Based Varnished</i>

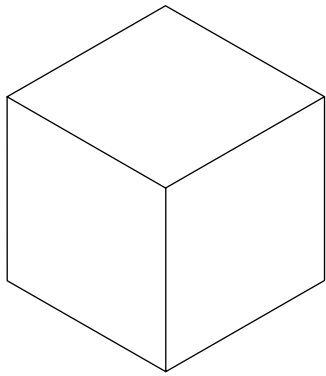

3D THERMO
400x230 mm

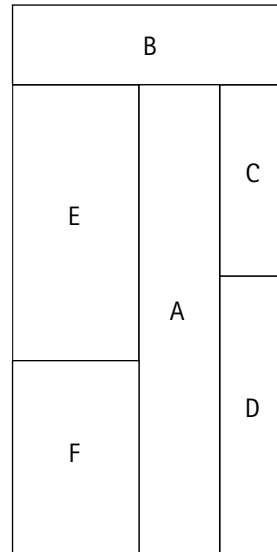

PATCHWORK

- A = 850x150 mm
- B = 500x150 mm
- C = 350x120 mm
- D = 500x120 mm
- E = 500x230 mm
- F = 350x230 mm

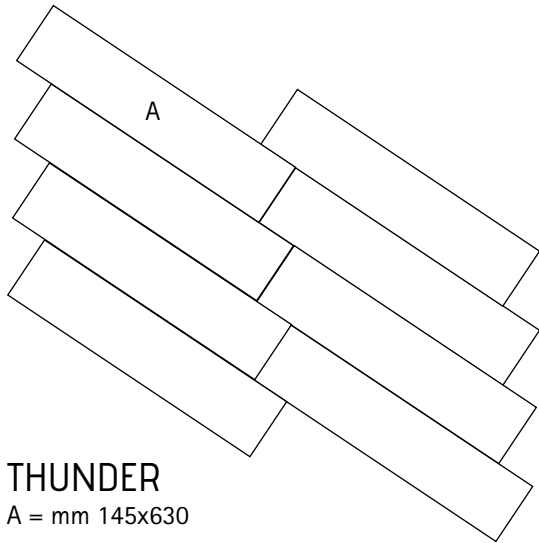

THUNDER
A = mm 145x630

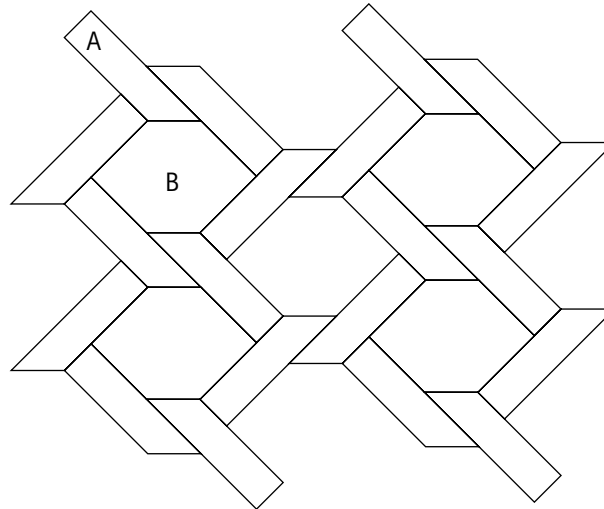

INDIAN PATTERN

- A = 70x280 mm
- B = 297x198 mm

TRAMA

- A = 230x230 mm
- B = 230x690 mm

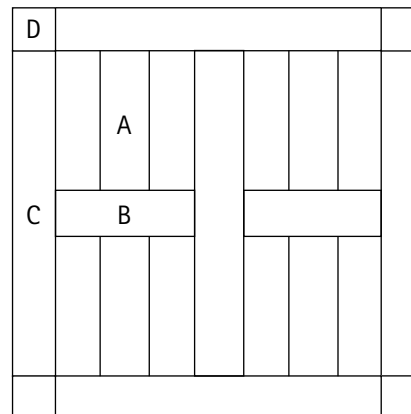
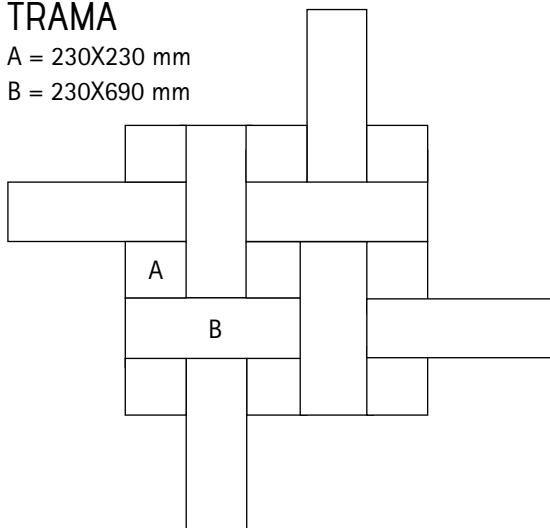

QUADRO

- A = 150x450 mm
- B = 150x450 mm
- C = 150x1050 mm
- D = 150x150 mm

MONPAR.COM



La riproduzione fotografica dei colori, anche se molto vicini alla realtà, deve ritenersi a carattere puramente indicativo.
Monpar si riserva il diritto di apportare alle proprie finiture e formati, senza alcun preavviso, qualsiasi modifica ritenesse opportuna.
The photographic reproduction of the colours, even if really close to the reality, must be considered purely indicative.
Monpar reserves the right to make changes at its finishes and formats, without any notice, if deemed appropriate.

Monpar



Monpar 

Monpar srl
Via Brigata Alpina Julia, 1 - 36045 Alonte (Vicenza)
Tel 0444 834983 - Fax 0444 834810
monpar@monpar.com - www.monpar.com